



Assembly instruction - Repair sleeves TMR -

EN

For sealing or covering damaged outer sheaths.

- ⓘ • Suitable devices for shrinking are: gas burner (propane or butane gas), hot-air gun.
- When using a burner, set the device to a gentle, yellow flame. Avoid sharp, blue flame tips.
- Keep the burner in constant motion so as to avoid local overheating!
- Hold heat source in the direction of shrinking during the shrinking process so that the shrink sleeve is pre-heated accordingly.
- Shrinking temperature: 120 - 140°C.
- Prior to mounting, carry out a careful check for damage areas.

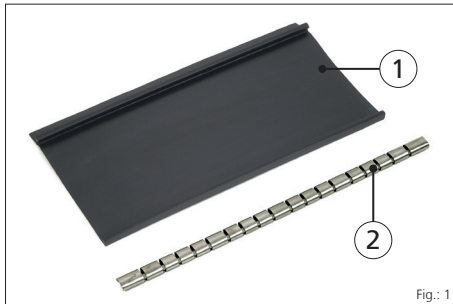


Fig.: 1

Legend for fig.: 1

- 1 Longitudinally split repair sleeve with coating on the inside
- 2 Sealing rail

Description	Area of use [mm]
TMR 34/10	Ø 34 - 10
TMR 53/13	Ø 53 - 13
TMR 85/22	Ø 85 - 22
TMR 107/29	Ø 107 - 29
TMR 143/36	Ø 143 - 36

Dimensions table

1 Assembly TMR



Fig.: 2

In the area of the sleeve to be shrunk, clean the cable sheath with solvent-free cable cleaner (KR M.T.X.) and roughen using an emery cloth (see fig.: 2).



Fig.: 3

Peel off the protective foil from the adhesive area of the sleeve (see fig.: 3).



Fig.: 4

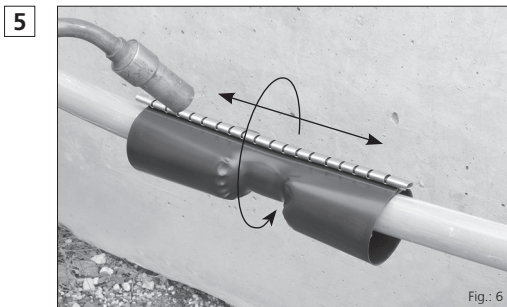
Position the shrink sleeve centrally around the damaged area (see fig.: 4).

- ⓘ • The shrink sleeve has to cover both sides of the damage area by at least 50 mm.

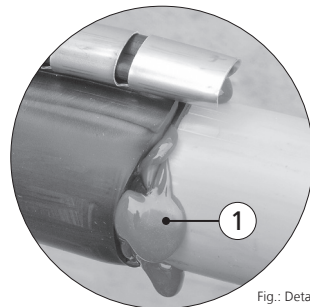


Fig.: 5

Push sealing rail up until flush (see fig.: 5).

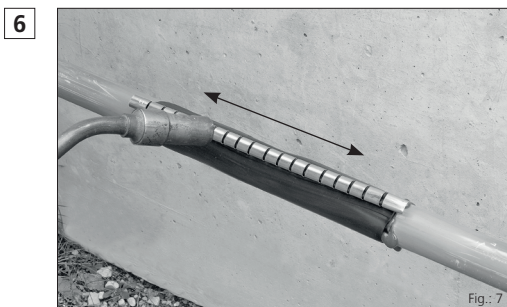


In order to avoid air pockets, shrink evenly from the middle outwards and all around to both sleeve ends until adhesive escapes at both ends (see fig.: Detail). Start in the area opposite the sealing rail (see fig.: 6).



Legend for fig.: Detail

1 Escaping adhesive



Once both sleeve ends have been shrunk in this way and the sleeve is evenly positioned, heat up the area of the sealing rail and the overlapping sleeve sector along its entire length. Allow sleeve to cool to ambient temperature before applying mechanical force (see fig.: 5).

ⓘ For use with insulated cables and cords in power installations upto 30KV. The relevant national electrical standards and rules must be considered and followed.

Hauff-Technik GmbH & Co. KG

Robert-Bosch-Straße 9
89568 Hermaringen, GERMANY

Tel. +49 7322 1333-0

Fax +49 7322 1333-999

office@hauff-technik.de